



智弘科技

Jhjh-Hong Technology Co., Ltd.

SPECIFICATION FOR APPROVAL

MODEL NAME : MITSUBISHI CR2032

JHT P/N : CMCR203221

DATE : 2020/09/23

REVISION : A

REMARK



JHT APPROVAL :		
EDITOR	CHECK	APPROVED

Jhjh-Hong Technology Co., LTK.

智弘科技股份有限公司

T +886 2 2298 9236

6F, No. 15 WuChuan Road, Wu-Ku Industrial

248 新北市新北產業園區五權路 15 號 6 樓

F +886 2 2290 1657

Park, New Taipei City 248, Taiwan

<http://www.jht-energy.com>

E service@jht-energy.com

TITLE	mitsubishi CR2032	REVISED	A
		PAGE	2 /18

REVISION AND UPDATES

REVISED	DESCRIPTION	DATE
A	First issue	2020/09/23

SPECIFICATION
FOR LITHIUM BATTERY

Model: CR2032
(Made in China)

Date : September 8, 2020

MITSUBISHI ELECTRIC HOME APPLIANCE CO., LTD
BATTERY DEPT.

PRODUCT SPECIFICATION

1. Applicability:

This specification is applicable to the following product:

Coin type manganese lithium battery **CR2032**

2. Battery type and ratings:

- 2.1. Battery type:** CR2032
2.2. Nominal voltage: 3.0V
2.3. Nominal capacity: 220mAh (on continuous discharge at 20°C under 15KΩ load to
2.4 Outer dimensions: Outer dimensions shall be as shown in Fig. 1, Battery Dimensions.
2.5 Weight: Approx. 3.0 g
2.6 Production country: China
2.7 Guarantee : 1 year

3. Quality requirements:

3.1 Dimensions: Dimensions of batteries when tested in accordance with Subparagraph shall be as shown in Fig.. Battery dimensions.

3.2 Appearance: Battery shall have no deformation, dent, stain, leakage and camber or burr on their sealing members, which may adversely affect their appearance, performance and commercial value. There shall be no coatings or other foreign objects on the surface of terminals which may adversely affect actual use or performance of batteries.

3.3 Characteristics :

(1) *Open-circuit voltage:* Open-circuit voltage of batteries when tested in accordance with Subparagraph 3.3.2 shall meet the requirement set forth in Table 1.

(2) *Closed-circuit voltage:* Closed-circuit voltage of batteries when test in accordance with Subparagraph 3.3.2 shall meet the requirements set forth in Table 1.

[TABLE 1]

TEST ITEMS	TEMPERATURE	INITIAL	AFTER 12 MONTHS	REMARKS
Open-circuit Voltage	20±2°C	3.0V TO 3.4V	3.0V TO 3.4V	
Closed-circuit Voltage	20±2°C	3.0V TO 3.4V	3.0V TO 3.4V	Load Resistance 15KΩ . 0.8 Sec.

(3) *Service life:* Service life of batteries when tested in accordance with Subparagraph 3.3.3 shall meet the requirements set forth in Table 2.

[TABLE 2]

TEST ITEMS	TEMPERATURE	INITIAL	AFTER 12 MONTHS	REMARKS
Service Life	20±2°C	1100 Hrs. Or Longer	1078 Hrs. or Longer	Continuous Discharge Under 15KΩ Load to 2.0V End-Voltage

(4) Service life after storage at high temperature: Service life of batteries when tested in accordance with Subparagraph 3.3.4 shall meet the requirements set forth in Table 3

[TABLE 3]

TEST ITEM	STORAGE TEMP	STORAGE PERIOD	REQUIREMENT	REMARKS
Service Life After Storage At High Temperature	60 ±2°C	20 Days	1078Hrs Minimum	Continuous Discharge At 20± 2°C Under 15KΩ Load To 2.0V End-Voltage After Storage.

(5) Leakage characteristics: Batteries when tested in accordance with Subparagraph 3.3.5 shall have no leakage.

[TABLE 4]

TEST ITEM	REQUIREMENT	TEST CONDITIONS
Leakage Characteristics	No Leakage	Temperature: 60 ± 2°C, Relative Humidity: 70% Storage: 30 Days Shall Be Inspected By Visual Means

(6) Self-discharge: Self-discharge of batteries when tested in accordance with Subparagraph 4.5.2 shall be as set forth in Table 5.

[TABLE 5]

TEST ITEM	REQUIREMENT	TEST CONDITIONS
Self-discharge	2% or Below	Continuous Discharge Under 15KΩ Load To 2.0V End-voltage After 12 Months Storage At 20°C. (To Obtain From The Mean Value Of The Same Lot)

4. Testing:

4.1 Test conditions :

4.1.1 Initial test :Initial test must be done within 1 months from delivery

4.1.2 Temperature and humidity: Unless otherwise specified elsewhere, tests shall be conducted at ordinary temperature (20±2°C) and ordinary humidity (65±5%RH).

4.2 Storage of test specimen batteries :

4.2.1 Specimen batteries to be tested shall be kept at the ambient temperature of 25°C or below and at the relative humidity of 75% or below.

4.2.2 Storage at less than -20°C can deform the plastic parts and may cause a leakage.

4.2.3 To prevent self-discharge caused by corrosion or decrease of insulation, humidity during storage shall be less than 75%RH without dewing on battery.

4.3 Measuring instruments and devices :

4.3.1 Dimensions: Outer micrometers specified in JYG26-95, dial gauges specified in JIS B 7503, and vernier callipers specified in JYG30-92 or those having equal or better accuracy shall be used.

4.3.2 DC voltmeters: The tolerance shall be $\pm 0.01V$ and the input resistance rating shall be $10M\Omega$ or more.

4.3.3 Load resistance: Load resistance shall include resistance throughout external circuits, and its tolerance shall be $\pm 0.5\%$.

4.4 Test methods :

4.4.1 Dimensions: Dimension shall be measured with instruments specified in Subparagraph 4.3.1 above, provided that either one or both sides of such instruments shall be insulated in measuring the overall height of the batteries.

4.4.2 Appearance: Appearance of batteries shall be inspected by visual means.

4.4.3 Open-circuit voltage: Test specimen batteries shall be kept for 8 hours or longer at the ambient temperature specified in Table 1, and then the voltage between both terminals shall be measured at the same ambient temperature with a voltmeter as specified in Subparagraph 4.3.2.

4.4.4 Closed-circuit voltage: Test specimen batteries shall be kept for 8 hours or longer at the ambient temperature specified in Table 1. and then the voltage between both terminals shall be measured with a voltmeter as specified in Subparagraph 4.3.2 while the specified load is connected between both terminals at the same ambient temperature as specified above; provided that the measured value shall be based on meter reading taken 0.8 seconds after the circuit is closed.

4.4.5 Service life: Test specimen batteries shall be kept for 8 hours or longer at the ambient temperature specified in Table 2. and shall then be continuously discharged at the same ambient temperature and through the specified load resistance. The discharge shall be continued until the terminal voltage of the test specimens falls below the discharge end-point voltage of 2.0V, and the time during which the terminal voltage has been maintained equal to and above the discharge end-point voltage shall be taken as the service life.

4.4.6 Service life after high-temperature storage: Test specimen batteries, after having been stored at the temperature and period specified in Table 3, shall be kept for 12 hours or longer at ordinary temperature ($20\pm 2^{\circ}C$) and at ordinary humidity ($55\pm 20\%RH$) and shall then be continuously discharged through the load resistance $15K\Omega$ at ambient temperature of $20\pm 2^{\circ}C$. The discharge shall be continued until the voltage falls below the discharge end-point voltage of 2.0V, and the time during which the voltage has been maintained equal to and above the discharge end-point voltage shall be taken as the service life.

4.4.7 NOTE: Discharge performance of primary batteries is specified in IEC 60086-2.

4.5 Other tests :

Tests specified below shall be conducted as required. Except as specified in this paragraph. Test methods be in accordance with the provisions of Paragraph 4.4.

4.5.1 Electrolyte leakage test: Test specimen batteries shall be examined for electrolyte leakage while they are kept at ordinary temperature and at ordinary humidity after having been stored at the temperature, humidity and period specified in Table 4.

4.5.2 Self-discharge: Test specimen batteries which have been stored for 12 month at the ambient temperature of 20±2°C and at the relative humidity of 65±20% shall be tested for service life in accordance with the method specified in Subparagraph 4.4.5

Self-discharge shall be determined in the following manner:

$$\text{Self-discharge rate (\%)} = \frac{X1 - X2}{X1} \times 100\%$$

X1: Average initial discharge life of batteries of the same lot

X2: Average discharge life after storage

4.6 Important Notes(Warranty)

4.6.1 The batteries are warranted to conform to the description contained in this specification for a period of twelve (12) months from the ex-factory date and any claim by customer (apparatus manufacturer or distributor) must be made within such period. During that warranty period, if the batteries are proved to become defective, non-defective and conforming batteries will be supplied in due course at sole expense of Mitsubishi Electric Home Appliance Co.,Ltd upon Mitsubishi Electric Home Appliance Co.,Ltd's own determination that this is apparently caused by negligence of Mitsubishi Electric Home Appliance Co.,Ltd.

4.6.2 This product, if defective in materials or workmanship, will be replaced free of charge, when returned to Mitsubishi Electric Home Appliance Co.,Ltd.

Replacement is the sole obligation under this warranty. This warranty expressly excludes incidental and consequential damages caused by use of, or inability to use, this product.

4.6.3 When customer does any work on the battery except instructions in this specifications, for example wire is soldered to the tab or battery surface directly, Mitsubishi Electric Home Appliance Co.,Ltd. Can not warrant any battery performance including safety and the customer shall undertake the responsibility of all damage caused by this battery.

4.6.4 Confirm and assure the matching and reliability of batteries on actual set or unit application with customer's responsibility

4.6.5 In the case of the following situation, it will be assured that Mitsubishi Electric Home Appliance Co.,Ltd dose not take responsibility.

- (1) When the appropriate handling, use, installation, or examination of batteries were not carried out.
- (2) When the instructions, attentions or warning mentioned in this specification were not followed.
- (3) When the rational instructions or advice of Mitsubishi Electric Home Appliance Co.,Ltd were not followed.

4.6.6 When this specifications is not returned in 6 months from issued date. This specification is deemed to be.

5. Markings:

5.1 Markings on batteries :

5.1.1 Battery type: CR2032

5.1.2 Brand of battery: **MITSUBISHI ELECTRIC**

5.1.3 Polarity : + [(-) shall not be indicated]

5.1.4 Manufacturing marks : The year and month of production shall be marked on the negative (-) terminal side

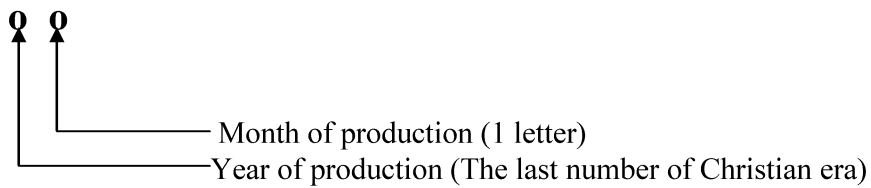

[[Example] 01..... Manufactured in January 2020

0X Manufactured in October 2020

0Y Manufactured in November 2020

0Z Manufactured in December 2020

Month of production.

- January to September -- 1- 9

- Oct, Nov, Dec, -----X, Y, Z

RATINGS OF MANGANESE DIOXIDE LITHIUM BATTERY

(TYPE: CR2032)

CLASSIFICATION	MANGANESE DIOXIDE LITHIUM PRIMARY BATTERY	
BATTERY SYSTEM	COIN TYPE MANGANESE DIOXIDE LITHIUM BATTERY	
BATTERY TYPE	CR2032	
NOMINAL VOLTAGE	3.0V	
NOMINAL CAPACITY	220mAh (ON CONTINUOUS DISCHARGE UNDER 15K Ω load to 2.0V end-point)	
STANDARD DISCHARGE CURRENT	0.2mA	
WEIGHT	APPROX. 3.0g	
OUTER DIMENSIONS	DIAMETER OVERALL HEIGHT	ϕ 20.0 (+0/-0.3)mm 3.2(+0/-0.3)mm
USABLE TEMPERATURE RANGE	-20°C ~ +70°C	
STORAGE TEMPERATURE RANGE	0°C~30°C	
STORAGE HUMIDITY RANGE	40%~75%	

- Nominal capacity indicates duration until the voltage drops down to 2.0V when discharged at a nominal discharge current at 20 deg. C.
- When using these batteries at temperatures outside the range of 0 to +40 deg. C, please consult the supplier or retailer you purchased the product from in advance for conditions of use.
- Dimensions and weight are for the battery itself, but may vary depending on the shape of terminals or other factors

The Appearance Of CR2032



E+ & E mark is one of our control mark

The Dimensions Of CR2032

Fig.1

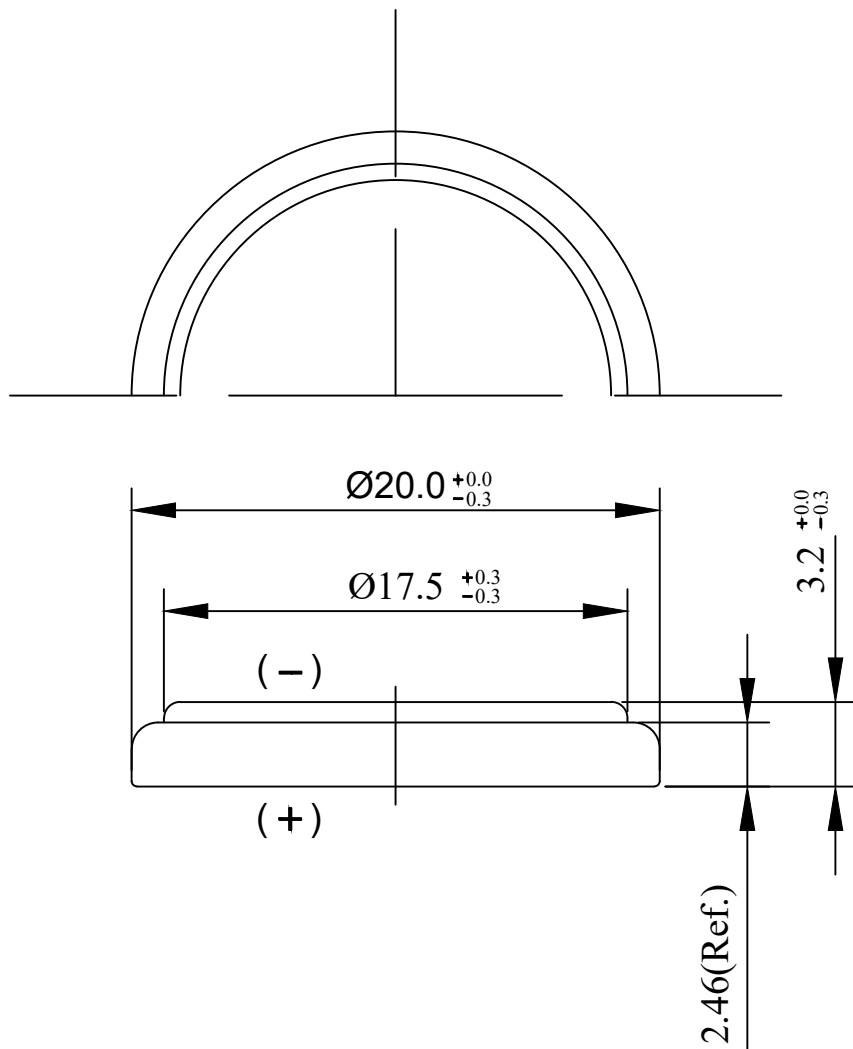

Specifications

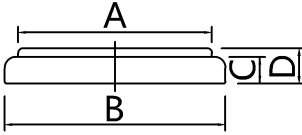
Nominal Voltage	3V	Dimensions (mm) 	A	$\text{Ø}17.5^{+0.3}_{-0.3}$
Nominal Capacity	220(mAh)		B	$\text{Ø}20.0^{+0.0}_{-0.3}$
Continuous standard load	15(K Ω)		C	2.46(Ref.)
Operating temperature	-20~70°C		D	$3.2^{+0.0}_{-0.3}$
Weight	3.0 (g) (Ref.)			

Discharge characteristics

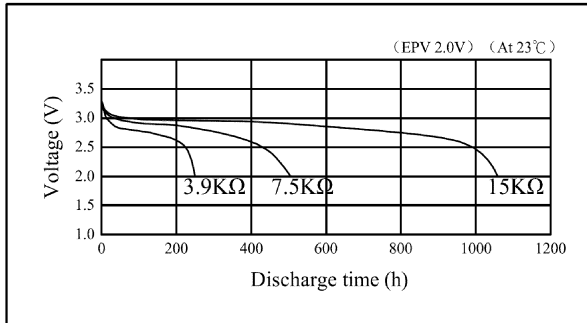

Temperature characteristics

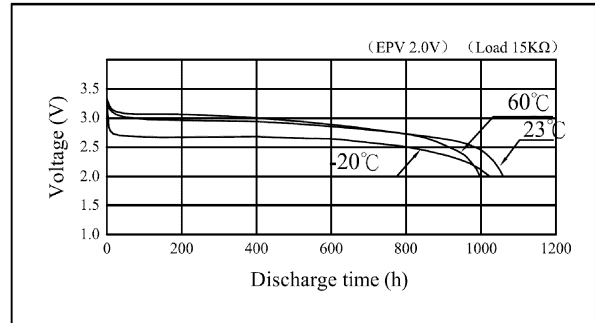

- Initial test: A test commencing within one month after delivery.
- Stored test: A test conducted after 12 months storage under the specified conditions after delivery.

6. Precautions

●Precautions in Designing

To use the battery efficiently, observe the following precautions.

1. Confirm the standard discharge current surely when batteries are used.

※This battery is not for heavy loading discharge.

Model	Standard discharge current
CR2032	0.2mA

2. Usage as main power source

- (1) Selection of battery

Select the most appropriate battery considering the electric property of equipment.

- (2) A number of use batteries and usage

Keep under 3 batteries to use for Lithium coin battery.

Do not mix any different brands when some batteries are used together.

Set in a battery charge protection equipment when it is used connecting in parallel.

- (3) Circuit design

Set apart battery circuit from other power circuits.

Set in a fuse or something safe parts in a circuit

3. Use as auxiliary power

- (1) Circuit design

Keep the circuit individually preventing being charged or forced discharge by main power source.

- (2) Circuit design (for back-up memory)

Set up a Diode and protection circuit to prevent being charged to a battery when a battery is connected to main power source circuit.

■Precautions in Designing a Memory Backup Circuit

A primary lithium battery is not rechargeable.

When used for memory backup in combination with another power source, current may flow into the battery from the other source. To prevent this, include a protection diode and resistor in the circuit so that no battery charging or over discharging can occur.

Allowable Range of Diode Back-Leakage Current

To prevent the battery from being charged by the main power source, be sure to use a back-current prevention diode and a protection resistor. Select a silicon diode or a Schottky diode with minimum leakage current, and design the circuit so that the amount of charging due to leakage current does not exceed 1% of the nominal battery capacity over the total period of use.

{Backup Circuit Example}

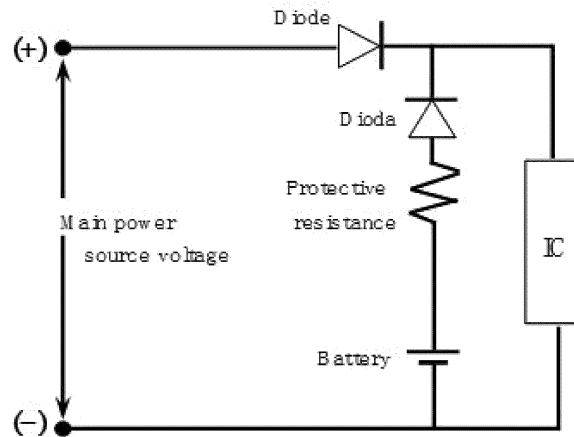

Back-current Prevention Diode and Protection Resistor Used

■ Maximum Allowable Charge Current to Battery

A protection resistor is needed to prevent diode failure from allowing a large current to flow into the battery. The following table shows the maximum allowable charging current in the event of diode failure.

Model	Maximum allowable charging current
CR2032	10mA

{How to Calculate Protection Resistance R}

Protection resistance R must exceed the value calculated in the following formula:

$$R \geq \frac{V(\text{Main power source voltage})}{I(\text{Maximum allowable charge current per battery})}$$

※ In this equation, the worst-case battery voltage (0) is assumed.

4. Battery holder and battery chamber

- (1) Design a battery chamber which the electric is not connected when a battery was reversed.
Describe the correct loading direction of battery surely and indelibly on a battery chamber.
- (2) Design a battery chamber which other size batteries can not be inserted or connected.
- (3) Design a battery chamber which is outgassed easily.
- (4) Design a battery chamber preventing water entering.
- (5) Add the feature of explosion protection to a battery chamber when it is sealed.
- (6) Set a battery chamber apart from heat source equipment.
- (7) Design a battery chamber which children can not pull out easily.

5. Interface and terminal

- (1) Make sufficient quality and shape for electric connection.
- (2) Design an attached circuit which prevents the batteries reversed.
- (3) Shape the battery preventing from being reversed.
- (4) Do not solder or weld to batteries directly.

6. List the precautions

(1) Main body

Specify the loading direction of battery on battery chamber.

(2) Manual

List the precautions how to handle batteries.

7. Do not solder the battery directly. Excessive heating may cause deformation of the battery components such as the gasket, which may lead to the battery swelling, leakage, explosion or ignition.
8. Observe the soldering condition for the tabbed battery to be specified by the manufacturer. Choose the tabbed battery if soldering is required.
Excessive heating may cause deformation of the gasket, leakage or performance deterioration of the battery. Assure not to exceed the battery temperature higher than 60°C at soldering.
9. Use nickel-plated iron or stainless steel for the terminals that contact the battery.
10. The contact pressure of the contacts should be no less than 2 to 10N (approx. 200 to 1000 gf).
11. Keep the battery contact terminal surfaces clean and free from moisture and foreign matter.
12. Before inserting the battery, check the battery contact terminals to make sure they are normal, not bent or damaged. Bent terminals may not make good contact with the battery or may cause it to short-circuit.
13. Do not overdischarge the battery lower than 0V. It may lead to reversed polarity and cause ignition, heating, leakage or explosion.
14. Lithium Manganese Dioxide Battery that is almost exhausted still maintains high output voltage that is almost the same as that of a fresh battery. Avoid using a mixture of old and new batteries; replace all batteries in a set with new ones
15. Lithium Manganese Dioxide Battery requires considerable time to regain their normal voltage after even a slight short-circuit. Therefore, should the battery be short-circuited, wait an adequate time for the battery to recover before measuring its electrical characteristics.
16. Use a high impedance ($1M\Omega$ or higher) voltmeter to measure battery voltage.
17. Battery characteristics vary with type and grade, even when batteries are the same size and shape. When replacing batteries with new ones, be sure to carefully check the symbols and numbers on each battery.
18. Please design equipment so that infants cannot easily remove batteries and swallow them.
19. Consult the sales representative, when series or parallel connection of several batteries is required.

●Precautions for Mounting

Unlike other electronic components, Lithium Manganese Dioxide Battery(Coin-type) may be externally short-circuited before and after it is installed in circuit boards and without the power being turned on. This causes power drainage. As a result, the battery may lose its capacity before the equipment is even used. As short-circuits tend to occur in the following cases, please take care when handling the battery.

1. Overlapping Batteries

Lithium Manganese Dioxide Battery is shaped as shown below. It has exposed positive(+)and negative(-) metallic surfaces with a thin cylindrical seal, called the gasket, inbetween them. When the batteries are overlapped or mixed together in a disorderly way, their positive(+)and negative(-)terminals touch each other, causing short-circuits.

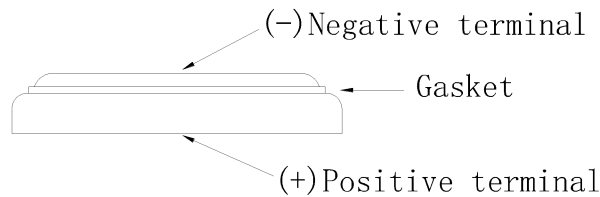

2. The Batteries Put in a Metallic Container or on a Metallic Plate

Similar to the overlapping battery problem, when the batteries are put in a metallic container or on a metallic plate, their positive(+)and negative(-)terminals may short-circuit through the conductive surface, depending on how the batteries are position.

3. When The Battery is Held with Metallic Tweezers

When held with a pair of metallic tweezers as shown, the battery short-circuits through the tweezers.

4. When The Battery Lead Plates Touch Each Other

When the battery lead plates bend and touch each other or other either terminal, the battery short-circuits.

5. Solder Bridges

Solder may bridge between circuit board conductors, causing a short-circuit and draining the battery.

6. Short-circuits through Soldering Irons

Similar to solder bridging, when the circuit board wiring is short-circuited by a soldering iron for an extended period the battery is drained and consumed. Complete short-circuits through soldering irons within 5 seconds.

7. Short-circuits through Piled Circuit Boards

When circuit boards with the batteries are piled on top of one another, their conductive traces may touch and form a battery discharge circuit that consumes the battery's power.

8. Discharge through Conductive Electrostatic Prevention Mats

Conductive mats are widely used to prevent static electricity from destroying semiconductors. If a circuit board with mounted battery is put on a conductive mat, the soldered conductors may touch the mat, providing a discharge path for the battery.

9. Improper Battery Mounting Polarity

When the battery's positive (+)and negative (-)terminals are reversed with respect to the battery mounting's polarity marks, the battery may be discharged, depending on the type of electric circuit.

10. Solder

When the battery lead plates are dipped in a molten solder bath, the battery is temporarily short-circuited. Therefore, complete dipping within 5 seconds.

● Handling Precautions

Please read and observe the following precautions thoroughly.

Lithium Manganese Dioxide Battery contains flammable materials, such as organic solvent. Improper battery handling may cause leakage, heating, explosion or ignition of the battery, which may lead to injury or product failure.

< WARNING >

- (1) Never charge the battery. Charging the battery may cause seethe of the battery electrolyte or increase of the battery internal pressure. Leakage, heating, explosion or ignition of the battery may be caused as a result of it.
- (2) Keep away from infants. If infant happens to swallow the battery, consult a doctor immediately.
- (3) In case of eye contact with the battery electrolyte, immediately flush eyes thoroughly with water, and consult a doctor.
- (4) In case the battery electrolyte happens to come into mouth, gargle well enough and consult a doctor immediately.
- (5) Do not heat or disposed in fire or water. Do not modify or disassemble the battery. It may damage the gasket, and may cause ignition, heating, leakage or explosion.
- (6) Do not short-circuit positive (+) and negative (-) terminals. Keep away from metal or other conductive materials. Jumbling the batteries of direct contact with positive (+) and negative (-) terminals and metal or other conductive materials may cause short.
- (7) When the battery is stored or disposed, isolate positive (+) and negative (-) terminals of the battery to avoid those terminals touch each other.
- (8) Insert the battery with positive (+) and negative (-) terminals correctly oriented.

< PRECAUTIONS >

- (1) Do not put the battery into microwave oven or drying machine.
- (2) Do not drop, apply excessive damage or deform the battery.
- (3) Do not mix the used battery together with the new battery or different type of batteries.
- (4) Do not store the battery in high temperature and high humidity location and where the battery is exposed to sunlight to avoid performance deterioration, swelling or leakage, of the battery.

CR2032 Packing Details

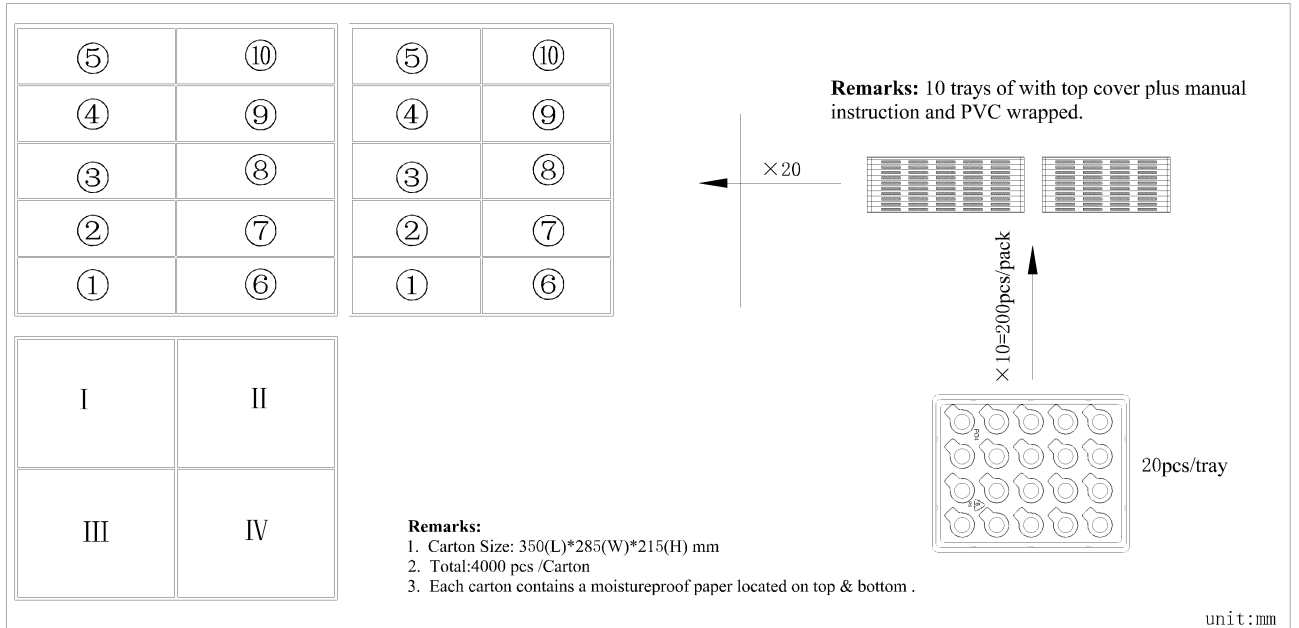

Remark:

1. Carton Size: 350(L)×285(W)×215(H) mm
2. Total: 4,000pcs/Carton
3. Each Carton contains a moisture proof paper located on top & bottom with an extra A4 size manual instruction.

Box packing dimensions and drawing

< CR2032 >
 Net Wt 11.4 kg
 Gross Wt 13.5 kg

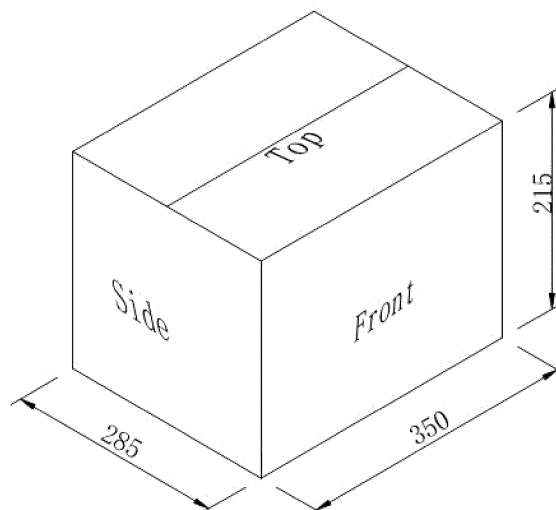

Tray Label

95±2

 UL CODE: MH21249	MITSUBISHI ELECTRIC HOME APPLIANCE CO.,LTD.	
 取り扱いの警告事項		
<p>電池が漏液、発熱、破裂、発火したり、けがや機器故障の原因となるので次のことを必ず守ること。</p> <ul style="list-style-type: none">●電池は乳幼児の手の届かない所に置く。電池を飲み込んだ場合は、死に至ることがあり直ちに医師に連絡し、指示を受ける。●充電、ショート、+-逆接続、新旧・異種電池混用、分解、加熱、火に入れる、水などで濡らすなどしない。●電池の液が目に入ったり、なめた場合は、すぐにきれいな水で洗い流し、医師の治療を受ける。●漏液や異臭があるときは、すぐに火気から遠ざける。●電池に直接はんだ付けしない。●電池を保管や廃棄する場合は他の電池や金属製のものと接触しないようにテープなどで端子部を絶縁する。●直射日光・高温・高湿の場所を避けて保管する。		
<p>WARNING: Risk of fire and burns. Do not recharge , disassemble, heat above 212°F, or incinerate. Keep battery out of reach of children and in original package until ready to use. Dispose of used batteries promptly. Never put batteries in mouth. Swallowing may lead serious injury or death, if ingested, use local procedures to call Poison Control or see a doctor immediately.</p>		
製品名(NAME)・入数(PCS)・製造コード(MANUFACTURE DATE)		
CR2032 (E) 200		
INSPECTION CONFORMATION		
[]		
[] [] [] []		

128±3

E+ & E mark is one of our control mark